

# STARTER BATTERIES

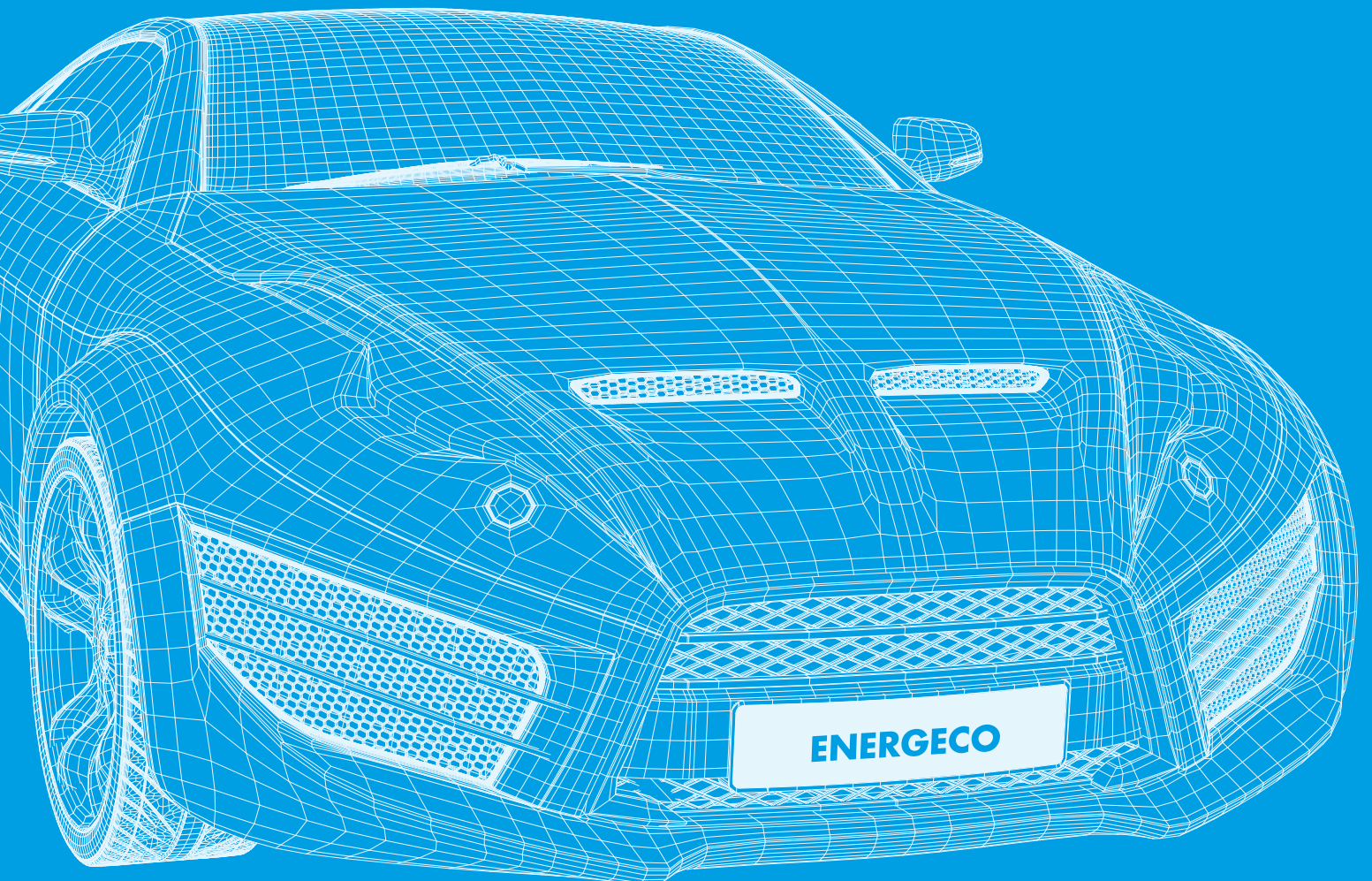

## 2<sup>ND</sup> GENERATION



# MIDAC - POWER PASSION



## ITINERIS START & STOP

Per veicoli dotati di motore Start&Stop. Disponibile in versione AGM (per motori Stop&Start con recupero di energia in frenata) e in versione EFB. Garantisce le prestazioni per decine di migliaia di micro cicli grazie all'avanzata tecnologia di produzione.

Ideal for Start&Stop applications. Available in the AGM version (for Stop&Start engines with braking energy recovery) and in the EFB version. It guarantees performance for thousands of micro cycles thanks to the advanced production technology.

Ideal für Start&Stop-Anwendungen. In der Version AGM (für Motoren mit Start&Stop und Energierückgewinnung beim Bremsen) und in Version EFB verfügbar. Dank der zukunftsweisenden Produktionstechnologie wird Leistungsfähigkeit für tausende von Mikro-Zyklen gewährleistet.

Idéale pour les applications Start&Stop. Disponible dans la version AGM (pour les moteurs Stop&Start avec récupération d'énergie pendant le freinage) et dans la version EFB. Elle garantit les prestations pour des milliers de micro cycles grâce à sa technologie de production avancée.

Ideal para aplicaciones Start&Stop. Disponible en versión AGM (para motores Stop&Start con recuperación de energía durante el frenado) y en versión EFB. Garantiza las prestaciones para miles de micro ciclo gracias a la avanzada tecnología de producción.

## SECURITAS

Massima potenza di avviamento ( +30% di corrente di spunto ) per garantire le prestazioni su mezzi che richiedono un consumo elevato di energia, anche in condizioni estreme. Dotata di doppio coperchio e sistema a labirinto integrato per il massimo della sicurezza.

Maximum starting power (+30% in inrush current) to guarantee performance on vehicles that require high energy consumption, even in extreme conditions. Equipped with double lid and integrated labyrinth system for maximum safety.

Maximale Anlasserleistung ( +30% Startstrom) zur Gewährleistung der Performance von Fahrzeugen, die einen hohen Energieverbrauch aufweisen, auch unter extremen Bedingungen. Ausgestattet mit doppeltem Deckel und integrierten Labyrinth-Zellen für maximale Sicherheit.

Puissance maximum de démarrage ( +30% en courant de pointe ) pour garantir les prestations sur des véhicules qui demandent une consommation élevée d'énergie, même dans des conditions extrêmes. Munie d'un double couvercle et d'un système à labyrinthe intégré pour une sécurité maximum.

Máxima potencia de puesta en marcha ( +30% en corriente de arranque) para garantizar las prestaciones sobre medios que requieren un alto consumo de energía, incluso en condiciones extremas. Compuesta por doble tapa y sistema de laberinto integrado para la máxima seguridad.

## CLAUSUM

Affidibilità e prestazioni elevate per fornire la massima potenza su motori tradizionali. Dotata di doppio coperchio e sistema a labirinto integrato per il massimo della sicurezza. Gamma completa per vetture Europee e di produzione Asiatica.

Reliability and high performance to provide maximum power on traditional engines without a Stop&Start system. Equipped with double lid and integrated labyrinth system for maximum safety. A complete range for European and also for Asian production cars.

Hohe Zuverlässigkeit und Performance zur Bereitstellung der maximalen Leistung für traditionelle Motoren ohne Start & Stop. Ausgestattet mit Doppeldeckel und integrierten Labyrinth-Zellen für maximale Sicherheit. Komplettes Sortiment für europäische und asiatische Fahrzeuge.

Fiabilité et prestations élevées pour fournir la puissance maximum sur les moteurs traditionnels sans dispositif START & STOP. Munie d'un double couvercle et d'un système à labyrinthe intégré pour une sécurité maximum. Gamme complète pour voitures européennes et de production asiatique.

Alta fiabilidad y prestaciones para proporcionar la máxima potencia en motores tradicionales sin sistema START & STOP. Compuesta por doble tapa y sistema de laberinto integrado para la máxima seguridad. Gama completa para vehículos Europeos y de producción asiática.



## VELOX

Prodotti con tecnologia Ca/Ca, non richiedono manutenzione. Sono il giusto compromesso tra prestazioni elettriche offerte e prezzo.

Ca/Ca Technology, Maintenance free. The right compromise between electrical performances and price.

Produziert mit Ca / Ca-Technologie benötigen sie keine Wartung. Sie sind der richtige Kompromiss zwischen elektrischen Dienstleistungen und Preis.

Technologie Ca/Ca, sans entretien. Un vrai compromis entre performance électrique et prix.

Tecnología Ca/Ca sin mantenimiento. Auténtico compromiso entre prestaciones eléctricas y precio.

## HERCULES

Prestazioni superiori per veicoli super equipaggiati. Bassissima auto scarica e assenza di manutenzione. Prodotta con separatore in lana vetro, sistema di intasamento e resina su ogni cella, per una resistenza alle vibrazioni superlativa. Massimo standard di sicurezza grazie al nuovo coperchio con labirinto interno e doppio "flame arrestor".

Superior performance for super-equipped vehicles. Very low car exhaust and no maintenance. Produced with glass wool separator, clogging system and resin on each cell, for superlative vibration resistance. Maximum level of safety thanks to the new cover with internal labyrinth and double "flame arrestor".

Höhere Performance für Fahrzeuge mit super Ausstattung. Sehr niedrige Selbstentladung und keinerlei Wartung. Mit Trennwand aus Glaswolle, System aus Abstandhaltern und Harz an jeder Zelle ausgestattet, für eine Vibrationsfestigkeit ohnegleichen. Maximaler Sicherheitsstandard dank des neuen Deckels mit internem Labyrinth und doppeltem "Flame Arrestor".

Performances supérieures pour véhicules super-équipés. Très faible autodécharge et absence de maintenance. Fabriquée avec un séparateur en laine de verre, un système anti-obstruction et une résine sur chaque cellule, pour une excellente résistance aux vibrations. Haut niveau de sécurité grâce au nouveau couvercle à labyrinthe interne et double "flame arrestor".

Rendimientos superiores para vehículos súper equipados. Muy baja auto descarga y ausencia de mantenimiento. Fabricada con separados en lana de vidrio, sistema de atascamiento y resina en cada celda, para una resistencia superlativa a las vibraciones. Máximo estándar de seguridad gracias a la nueva tapa con laberinto interno y doble "flame arrestor".

## POTENTIS

Ideale per la maggior parte delle applicazioni offre affidabilità e potenza per un lungo periodo. Assenza di manutenzione grazie all'impiego della tecnologia Ca/Ca. Disponibile anche in versione HD con separatore in lana vetro per un incremento della resistenza alle vibrazioni e un aumento dei cicli di vita.

Ideal for most applications, it offers reliability and power over time. No maintenance due to the use of Ca/Ca technology. Also available in the HD version with glass wool separator for increased resistance to vibration and to extend life cycles.

Ideal für die meisten Anwendungen bietet sie Zuverlässigkeit und Leistung über einen langen Zeitraum. Dank der Technologie Ca/Ca ist keine Wartung erforderlich. Auch in der Version HD mit Trennwand aus Glaswolle erhältlich, für gesteigerte Vibrations- und Zyklusfestigkeit.

Idéale pour la plupart des applications, elle offre une fiabilité et une puissance sur une longue durée. Absence de maintenance grâce à l'emploi de la technologie Ca/Ca. Disponible aussi en version HD avec un séparateur en laine de verre pour augmenter sa résistance aux vibrations et aux cycles de vie.

Ideal para la mayor parte de las aplicaciones ofrece fiabilidad y potencia durante un largo periodo. Ausencia de mantenimiento gracias al uso de la tecnología Ca/Ca. Disponible también en versión HD con separador de lana de vidrio para un aumento de la resistencia a las vibraciones y de los ciclos de vida.



ETN CODE	SHORT CODE	Ah 20h	A (-18°C) EN 7,5V 10"	DIMENSIONS MAX. MM			LAYOUT	TERMINAL TYPE	HOLD DOWN
				L	W	H			

### ITINERIS AGM - START & STOP - ABSORBENT GLASS MAT

<b>S560.901.068</b>	<b>IT2 AGM</b>	60	680	242	175	190	0	1	B3
<b>S570.901.076</b>	<b>IT3 AGM</b>	70	760	275	175	190	0	1	B3
<b>S580.901.080</b>	<b>IT4 AGM</b>	80	800	310	175	190	0	1	B3
<b>S595.901.085</b>	<b>IT5 AGM</b>	95	850	353	175	190	0	1	B3
<b>S605.901.095</b>	<b>IT6 AGM</b>	105	950	393	175	190	0	1	B3

### ITINERIS EFB - START & STOP - ENHANCED FLOODED BATTERIES

<b>S560.501.057</b>	<b>IT2 EFB</b>	60	570	242	175	190	0	1	B3
<b>S565.501.065</b>	<b>IT3B EFB</b>	65	650	275	175	175	0	1	B3 (+B4)
<b>S572.501.072</b>	<b>IT3 EFB</b>	72	720	275	175	190	0	1	B3
<b>S575.501.073</b>	<b>IT4B EFB</b>	75	730	310	175	175	0	1	B3
<b>S580.501.077</b>	<b>IT4 EFB</b>	80	770	310	175	190	0	1	B3

### SECURITAS - STANDARD DIN

<b>S555.059.052</b>	<b>S1</b>	55	520	207	175	190	0	1	B3
<b>S564.059.063</b>	<b>S2</b>	64	630	242	175	190	0	1	B3
<b>S582.031.077</b>	<b>S3</b>	82	770	275	175	190	0	1	B3
<b>S600.035.082</b>	<b>S4</b>	100	820	310	175	190	0	1	B3
<b>S600.038.086</b>	<b>S5</b>	100	860	353	175	190	0	1	B3

### SECURITAS - LOW DIN

<b>S550.065.050</b>	<b>S1B</b>	50	500	207	175	175	0	1	B3 (+B4)
<b>S563.077.061</b>	<b>S2B</b>	63	610	242	175	175	0	1	B3 (+B4)
<b>S574.018.072</b>	<b>S3B</b>	74	720	275	175	175	0	1	B3 (+B4)
<b>S584.039.078</b>	<b>S4B</b>	84	780	310	175	175	0	1	B3
<b>S592.038.080</b>	<b>S5B</b>	92	800	353	175	175	0	1	B3

### CLAUSUM - STANDARD DIN

<b>S544.008.042</b>	<b>H44</b>	44	420	175	175	190	0	1	B3
<b>S550.059.042</b>	<b>H50</b>	50	420	207	175	190	0	1	B3
<b>S555.060.047</b>	<b>H55</b>	55	470	207	175	190	0	1	B3
<b>S555.064.047</b>	<b>H55S</b>	55	470	207	175	190	1	1	B3
<b>S562.059.057</b>	<b>H62</b>	62	570	242	175	190	0	1	B3
<b>S562.065.057</b>	<b>H62S</b>	62	570	242	175	190	1	1	B3
<b>S574.012.068</b>	<b>H74</b>	74	680	275	175	190	0	1	B3

L= lenght W= width H= height

MIDAC S.p.A. si riserva il diritto di apportare in qualsiasi momento modifiche alle caratteristiche tecniche, alla tipologia costruttiva dei propri prodotti e/o alla gamma proposta senza obbligo di darne preventiva comunicazione scritta.

MIDAC S.p.A. reserves the right to carry out at any time any kind of modification to the technical data, to the manufacturing procedures and/or top the range of products, without giving previous written information.

MIDAC S.p.A. behält sich alle Rechte vor, jederzeit Änderungen in Art, Ausführung, Technik und Produktionsverfahren vorzunehmen und dies ohne vorherige mündliche oder schriftliche Ankündigung.

MIDAC S.p.A. se réserve le droit d'apporter de modifications dans n'importe quel moment aux caractéristiques techniques, à la typologie constructive des ses produits et/ou à la gamme proposée sans obligation de donner communication écrit en avance.

MIDAC S.p.A. se reserva el derecho de aportar en cualquier momento modificaciones a las características técnicas, a la tipologia constructiva de sus productos y/o de la gama propuesta sin obligación de dar una comunicación previa por escrito.



ETN CODE	SHORT CODE	Ah 20h	A (-18°C) EN 7,5V 10"	DIMENSIONS MAX. MM			LAYOUT	TERMINAL TYPE	HOLD DOWN
				L	W	H			
<b>S574.013.068</b>	<b>H74S</b>	74	680	275	175	190	1	1	B3
<b>S580.031.070</b>	<b>H80</b>	80	700	275	175	190	0	1	B3
<b>S600.035.080</b>	<b>H100</b>	100	800	310	175	190	0	1	B3
<b>S600.065.080</b>	<b>H100S</b>	100	800	310	175	190	1	1	B3
<b>S600.038.081</b>	<b>HL100</b>	100	810	353	175	190	0	1	B3

**CLAUSUM - LOW DIN**

<b>S547.065.045</b>	<b>H47B</b>	47	450	207	175	175	0	1	B3 (+B4)
<b>S562.077.057</b>	<b>H62B</b>	62	570	242	175	175	0	1	B3 (+B4)
<b>S572.018.068</b>	<b>H72B</b>	72	680	275	175	175	0	1	B3 (+B4)
<b>S582.039.074</b>	<b>H82B</b>	82	740	310	175	175	0	1	B3
<b>S592.015.080</b>	<b>H92B</b>	92	800	353	175	175	0	1	B3

**CLAUSUM - STANDARD JIS**

<b>S537.020.033</b>	<b>H37J</b>	37	330	187	127	225	0	3*	B0
<b>S537.022.033</b>	<b>H37JS</b>	37	330	187	127	225	1	3*	B0
<b>S537.038.033</b>	<b>H37J1</b>	37	330	187	135	225	0	3*	B1
<b>S545.077.030</b>	<b>H45E</b>	45	300	218	135	225	0	1	B1
<b>S545.079.030</b>	<b>H45ES</b>	45	300	218	135	225	1	1	B1
<b>S545.084.036</b>	<b>H45J</b>	45	360	237	127	225	0	3*	B0
<b>S545.051.036</b>	<b>H45JS</b>	45	360	237	127	225	1	3*	B0
<b>S550.041.042</b>	<b>H50J</b>	50	420	200	170	225	0	1	B0
<b>S550.042.042</b>	<b>H50JS</b>	50	420	200	170	225	1	1	B0
<b>S560.068.049</b>	<b>H60J</b>	60	490	230	170	225	0	1	B0
<b>S560.069.049</b>	<b>H60JS</b>	60	490	230	170	225	1	1	B0
<b>S570.029.056</b>	<b>H70J</b>	70	560	270	175	225	0	1	B3 (+B6)
<b>S570.024.056</b>	<b>H70JS</b>	70	560	270	175	225	1	1	B3 (+B6)
<b>S595.018.076</b>	<b>H95J</b>	95	760	303	175	225	0	1	B6
<b>S595.019.076</b>	<b>H95JS</b>	95	760	303	175	225	1	1	B6

L= lenght W= width H= height

\* Adapter from terminal type 3 to 1

**CONDIZIONI GENERALI  
DI VENDITA**

Relativamente alle condizioni generali di vendita  
fare riferimento a quanto pubblicato sul nostro sito  
[www.midacbatteries.com](http://www.midacbatteries.com)

**GENERAL SALES  
TERMS**

As to the General Sales Terms refer  
to the content insered in our web site  
[www.midacbatteries.com](http://www.midacbatteries.com)

**GENERALVERKAUFSKONDITIONEN**

Es gelten unsere Allgemeinen Geschäftsbedingungen,  
die sie auf unserer Webseite einsehen können  
[www.midacbatteries.com](http://www.midacbatteries.com)

**CONDITIONS GENERALES  
DE VENTE**

Relativement aux conditions générales de vente faire  
référence à tout ce qui a été publié sur notre site  
[www.midacbatteries.com](http://www.midacbatteries.com)

**CONDICIONES GENERALES  
DE VENTA**

En relación con las condiciones generales de venta  
remítirse a la información publicada en nuestra web  
[www.midacbatteries.com](http://www.midacbatteries.com)



ETN CODE	SHORT CODE	Ah 20h	A (-18°C) EN 7,5V 10"	DIMENSIONS MAX. MM			LAYOUT	TERMINAL TYPE	HOLD DOWN
				L	W	H			

### VELOX - STANDARD DIN

<b>524.015.018 (DRY)</b>	<b>C24</b>	24	180	187	128	167	0	4	B0
<b>524.030.018 (DRY)</b>	<b>C24S</b>	24	180	187	128	167	1	4	B0
<b>532.011.022 (DRY)</b>	<b>C32</b>	32	220	233	131	167	0	4	B0
<b>540.008.036</b>	<b>C40</b>	40	360	175	175	190	0	1	B3
<b>544.059.036</b>	<b>C44</b>	44	360	207	175	190	0	1	B3
<b>550.059.042</b>	<b>C50</b>	50	420	207	175	190	0	1	B3
<b>560.059.052</b>	<b>C60</b>	60	520	242	175	190	0	1	B3
<b>570.038.061</b>	<b>C70</b>	70	610	275	175	190	0	1	B3
<b>574.012.066</b>	<b>C74</b>	74	660	275	175	190	0	1	B3
<b>600.035.079</b>	<b>C100</b>	100	790	310	175	190	0	1	B3
<b>600.038.081</b>	<b>CL100</b>	100	810	353	175	190	0	1	B3
<b>610.042.095</b>	<b>C110</b>	110	950	393	175	190	0	1	B3

### VELOX - LOW DIN

<b>544.065.040</b>	<b>C44B</b>	44	400	207	175	175	0	1	B3 (+B4)
<b>560.077.052</b>	<b>C60B</b>	60	520	242	175	175	0	1	B3 (+B4)
<b>570.018.064</b>	<b>C70B</b>	70	640	275	175	175	0	1	B3 (+B4)
<b>580.039.070</b>	<b>C80B</b>	80	700	310	175	175	0	1	B3

### HERCULES - SHD (SUPER HEAVY DUTY)

<b>650.105.085</b>	<b>SHD150</b>	150	850	510	189	223	3	1	B0
<b>680.108.105</b>	<b>SHD180</b>	180	1050	513	223	223	3	1	B0
<b>730.103.125</b>	<b>SHD230</b>	230	1250	518	273	240	3	1	B0

### POTENTIS - HD (HEAVY DUTY)

<b>635.034.085</b>	<b>135AS</b>	135	850	510	189	223	3	1	B0
<b>650.020.090</b>	<b>150AS</b>	150	900	510	189	223	3	1	B0
<b>650.044.100</b>	<b>150MS</b>	150	1000	510	175	225	3	1	B3
<b>650.089.090</b>	<b>150B</b>	150	900	513	223	223	4	1	B3
<b>650.017.090</b>	<b>150BS</b>	150	900	513	223	223	3	1	B0
<b>680.089.100</b>	<b>180B</b>	180	1000	513	223	223	4	1	B3
<b>680.032.100</b>	<b>180BS</b>	180	1000	513	223	223	3	1	B0
<b>700.029.110</b>	<b>200B</b>	200	1100	513	223	223	4	1	B3
<b>700.088.110</b>	<b>200BS</b>	200	1100	513	223	223	3	1	B0
<b>725.016.120</b>	<b>225C</b>	225	1200	518	273	240	4	1	B0
<b>725.018.120</b>	<b>225CS</b>	225	1200	518	273	240	3	1	B0

L= lenght W= width H= height

MIDAC S.p.A. si riserva il diritto di apportare in qualsiasi momento modifiche alle caratteristiche tecniche, alla tipologia costruttiva dei propri prodotti e/o alla gamma proposta senza obbligo di darne preventiva comunicazione scritta.

MIDAC S.p.A. reserves the right to carry out at any time any kind of modification to the technical data, to the manufacturing procedures and/or top the range of products, without giving previous written information.

MIDAC S.p.A. behält sich alle Rechte vor, jederzeit Änderungen in Art, Ausführung, Technik und Produktionsverfahren vorzunehmen und dies ohne vorherige mündliche oder schriftliche Ankündigung.

MIDAC S.p.A. se réserve le droit d'apporter de modifications dans n'importe quel moment aux caractéristiques techniques, à la typologie constructive des ses produits et/ou à la gamme proposée sans obligation de donner communication écrit en avance.

MIDAC S.p.A. se reserva el derecho de aportar en cualquier momento modificaciones a las características técnicas, a la tipologia constructiva de sus productos y/o de la gama propuesta sin obligación de dar una comunicación previa por escrito.

12  
VOLT



ETN CODE	SHORT CODE	Ah 20h	A (-18°C) EN 7,5V 10"	DIMENSIONS MAX. MM			LAYOUT	TERMINAL TYPE	HOLD DOWN
				L	W	H			

**POTENTIS**

600.032.080	100G	100	800	330	175	205	0	1	B3
600.033.080	100GS	100	800	330	175	205	1	1	B3
610.029.074	110B1	110	740	343	172	230	0	1	B1
610.028.074	110B0	110	740	343	172	230	0	1	B0
610.027.074	110BS	110	740	343	172	230	1	1	B0
620.029.083	120B1	120	830	343	172	230	0	1	B1
620.033.082	120M	120	820	510	175	225	4	1	B3
625.026.076	125AT	125	760	343	172	290	0	1	B0
635.044.100	135MS	135	1000	513	175	210	3	1	B3
640.011.090	140MT	140	900	510	175	205	0	1	B1

L= lenght W= width H= height

**MAIN FEATURES**



LABIRINTO INTERNO  
INTERNAL LABYRINTH



SEPARATORI LANA VETRO  
GLASS FIBER SEPARATOR



TAPPO CON GUARNIZIONE  
O-RING



INTASATORI  
CELL CONSTRAINING



RESINA A CALDO  
HOT MELT



+30% DI SPUNTO  
HIGHER COLD CRANKING CURRENT



START & STOP



PASTIGLIA ANTI-FIAMMA  
FLAME ARRESTOR



SISTEMA ANTI-FUORIUSCITA ACIDO  
ANTI SPILLING SYSTEM

	START & STOP	+30%	O-RING	LABIRINTO INTERNO	SEPARATORI LANA VETRO	INTASATORI CELL	PASTIGLIA ANTI-FIAMMA	SISTEMA ANTI-FUORIUSCITA ACIDO	RESINA A CALDO
ITINERIS AGM	✓		✓		✓		✓		
ITINERIS EFB	✓			✓	✓		✓		
SECURITAS		✓		✓			✓		
CLAUSUM				✓			✓		
HERCULES SHD			✓	✓	✓		✓	✓	
POTENTIS HD				✓	✓				✓

**LAYOUT**

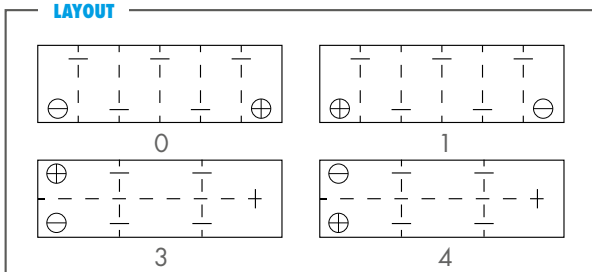

**TERMINAL-TYPE**

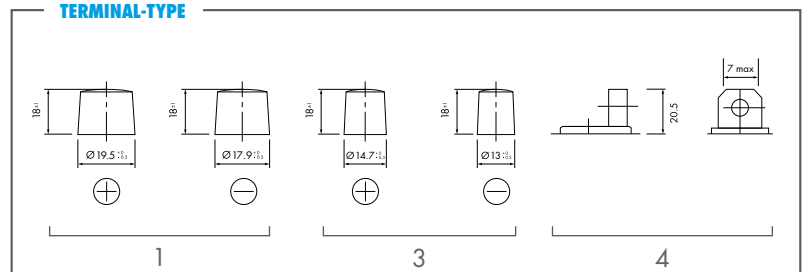

**HOLD DOWN**

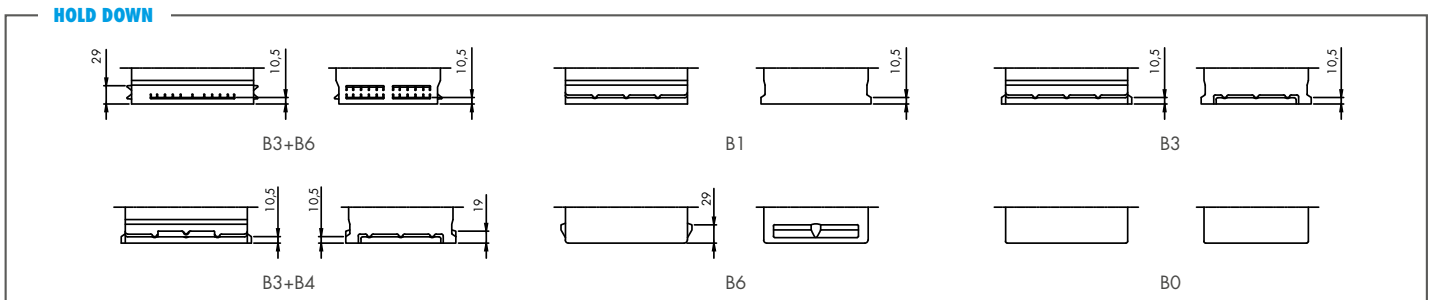



#### **MIDAC S.p.A.**

VIA A.VOLTA, 2 - Z.I. - 37038 SOAVE (VERONA) - ITALIA  
TEL. +39 045 61 32 1 32 - FAX +39 045 61 32 1 33  
E-mail: [midac@midacbatteries.com](mailto:midac@midacbatteries.com)

#### **MIDAC DEUTSCHLAND GMBH**

MARKGRÖNINGER STR. 36 - 71701  
SCHWIEBERDINGEN - DEUTSCHLAND  
TEL. +49 7150 3511315 - FAX +49 7150 3511320  
E-mail: [vertrieb@midacbatteries.com](mailto:vertrieb@midacbatteries.com)

#### **MIDAC NEDERLAND BV**

KEPLERLAAN 10 - 6716BS EDE - NEDERLAND  
TEL. +31 318 678230 - FAX +31 318 678231  
E-mail: [verkoop@midacbatteries.com](mailto:verkoop@midacbatteries.com)

#### **MIDAC AUSTRALIA**

2/32 BLUETT DRIVE - SMEATON GRANGE, NSW - 2567  
TEL. +61 02 4647 1422 - FAX +61 02 4648 1684  
E-mail: [midac.australia@midacbatteries.com](mailto:midac.australia@midacbatteries.com)

#### **BATTERIUNION AB - SWEDEN**

FAKTURAVÄGEN 6 - S-175 62 JÄRFÄLLA  
TEL. +46 8 795 28 50 - FAX +46 8 795 28 69  
E-mail: [infose@midacbatteries.com](mailto:infose@midacbatteries.com)

#### **MIDAC FRANCE S.A.R.L.**

Z.I. - ROUTE DE COLMAR BP 70  
F-68502 GUEBWILLER, CEDEX - FRANCE  
TEL. +33 03 89 622380 - FAX +33 03 89 622375  
E-mail: [contact@midacbatteries.com](mailto:contact@midacbatteries.com)

#### **MIDAC UK LTD**

15 RADFORDS FIELD - MAESBURY ROAD - OSWESTRY  
SHROPSHIRE - SY10 8RA - UK  
TEL. +44 01691 663111 - FAX +44 01691 653066  
E-mail: [enquiries@midacbatteries.com](mailto:enquiries@midacbatteries.com)  
SALES OFFICE IRELAND  
141 LOUGHGALL ROAD - COUNTY ARMAGH  
BT 618EW - IRELAND  
TEL. + 44 02837 511744

[www.midacbatteries.com](http://www.midacbatteries.com)



#### **MIDAC SPA HEADQUARTERS, SOAVE, VERONA, ITALY**

Unica realtà a produrre batterie avviamento, trazione e stazionarie in un singolo stabilimento produttivo, è diventata una delle aziende leader in Europa con prodotti distribuiti in tutto il mondo.

*The only company that produces Automotive, Motive power and Stationary batteries in the same manufacturing plant, it has become one of the leading companies in Europe and its products are sold worldwide.*

#### **MIDAC PRODUZIONE VERDE**

Midac utilizza l'energia pulita prodotta dal proprio impianto fotovoltaico per la produzione di batterie e accumulatori, evitando l'emissione di 945 tonnellate di CO<sub>2</sub> ogni anno.

#### **MIDAC FABRICATION ÉCOLOGIQUE**

Midac utilise l'énergie propre provenant de votre système photovoltaïque pour la production de batteries et d'accumulateurs, en évitant l'émission de 945 tonnes de CO<sub>2</sub> chaque année.

#### **MIDAC GREEN PRODUCTION**

Midac uses clean energy produced by its own photovoltaic system to produce batteries and accumulators, avoiding the emission of 945 CO<sub>2</sub> tons every year.

#### **MIDAC GRÜNE ENERGIE**

Midac verwendet grüne Energie, welche von der eigenen Solaranlage geliefert wird, um ihre Batterien und Akkumulatoren herzustellen. So sind wir in der Lage 945 Tonnen an CO<sub>2</sub> einzusparen.

#### **MIDAC PRODUCCIÓN DE ENERGÍA VERDE**

Midac utiliza energía limpia producida por su propio sistema fotovoltaico para producir baterías y acumuladores, evitando la emisión de 945 toneladas de CO<sub>2</sub> cada año.

#### **MIDAC GRÖN PRODUKTION**

Midac använder ren energi som produceras av deras egna solceller för att producera batterier och ackumulatörer, genom detta så undviker man varje år utsläpp av 945 ton CO<sub>2</sub>.

